

"TRADER" SERVICE SHEET

544

MURPHY A4

AC SUPERHET

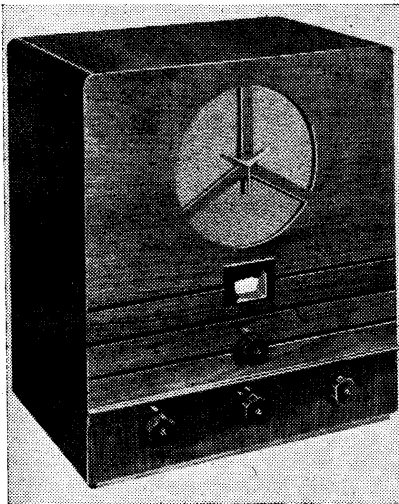

The Murphy A4 superhet.

Provision is made for the connection of a gramophone pick-up and an external speaker, and the HT smoothing circuit includes a tuned choke in addition to the speaker field and three electrolytic condensers.

A special model, identical with the above, except in the mains transformer primary circuit, is made for 100-110 V 40-100 C/S mains, while another model, with a special mains transformer, is made for 200-250 V mains of 25 C/S. The differences between the standard model and the two special models are described under "Mains Transformer T2."

Release date, all models: 1935.

CIRCUIT DESCRIPTION

Aerial input via coupling coils **L1, L2** to inductively coupled band-pass filter. Primary coils **L3, L4** are tuned by **C23**; secondary coils **L8, L9** by **C26**. Coupling by coils **L6 (MW)** and **L5, L6 (LW)** in common return path to chassis via **C1**. Image suppression by **L7**.

First valve (**V1, Mazda AC/Pen**) is an AF pentode operating as frequency changer. Reaction coupling is established between the oscillator anode circuit coils **L12 (MW)** and **L13 (LW)**, which are tuned by **C29**, and the reaction coils **L10 (MW)**

and **L11 (LW)** in the screen grid circuit. Parallel trimming by **C28 (MW)** and **C27 (LW)**; series tracking by **C5 (MW)** and **C4 (LW)**. Mixing occurs in the anode circuit, and the intermediate frequency is developed across **L14, C30**. **C3** is a very small coupling introduced to neutralise radiation in the aerial circuit at oscillator frequency.

Second valve (**V2, Mazda metallised AC/SGVM**) is a variable- μ RF tetrode operating as intermediate frequency amplifier with tuned-primary, tuned-secondary transformer couplings **C30, L14, L15, C31** and **C32, L16, L17, C33**.

Intermediate frequency 117 KC/S.

SG and GB potentials for **V2** are obtained from a potential divider **R4, R5, R6** and **R7**, the negative end of which returns to chassis via the aerial coupling coils **L1, L2** and **L7**. **R7**, whose slider goes directly to chassis, operates as the gain control of the receiver by varying the GB applied to **V2**. As the GB value is increased, the damping imposed across the aerial circuit by the diminishing value of the resistance of the lower portion of **R7** is progressively increased.

Triode second detector (**V3, Mazda metallised AC/HL**) operates on the anode bend system, the output from **L17** being

An output pentode valve is used as a frequency changer in the Murphy A4 receiver, a 4-valve (plus rectifier) 2-band superhet designed to operate on AC mains of 200-250 V, 40-100 C/S.

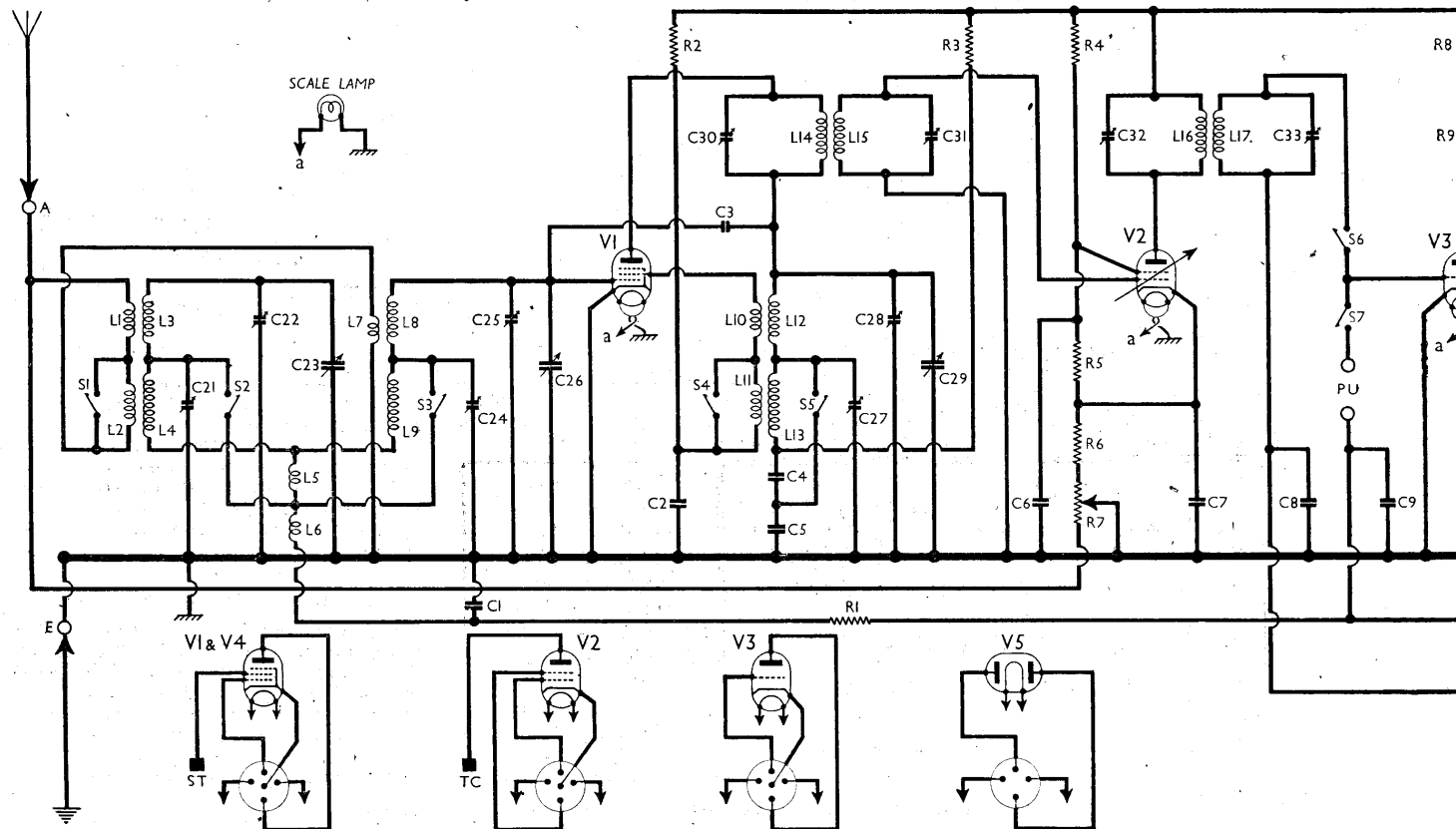

applied to the grid circuit via **S6**. Provision is made for the connection of a gramophone pick-up via a jack-type socket, of which switches **S6** and **S7** form a part. When the pick-up plug is inserted, **S6** opens to mute radio, and **S7** closes to connect the pick-up.

Resistance-capacity coupling by **R9**, **C12** and **R10**, via IF filter circuit comprising **R11**, **R12** and **C14**, between **V3** and pentode output valve (**V4**, Mazda AC/Pen). Variable tone control by **C16** and **R13**. Provision for connection of low impedance external speaker across secondary of output transformer **T1**.

IF filtering by **C11** in **V3** anode circuit, **R11**, **C14** and **R12** in **V4** control grid circuit, and **C15** in **V4** anode circuit.

HT current is supplied by full-wave rectifying valve (**V5**, Philips 1807). Smoothing by iron-cored choke **L20** and speaker field **L19** in negative HT lead to chassis, in conjunction with electrolytic condensers **C18**, **C19** and **C20** and shunt condenser **C17** across **L20**.

Fixed GB potentials for **V1**, **V3** and **V4** are obtained automatically from a potential divider comprising resistances **R14**, **R15**, **R16** and **R17**, which are connected across **L19**. Two tappings are provided for **V3**: one (about 7 V) is applied via **L17** and **S6** for radio operation, while the other (about 3 V) is applied via the pick-up and **S7**. For this reason, if the pick-up connection does not form a complete continuous circuit, a high resistance should be connected between the two input tags so that the bias shall be applied to the control grid during gramophone operation. A suitable value would be 500,000 Ω.

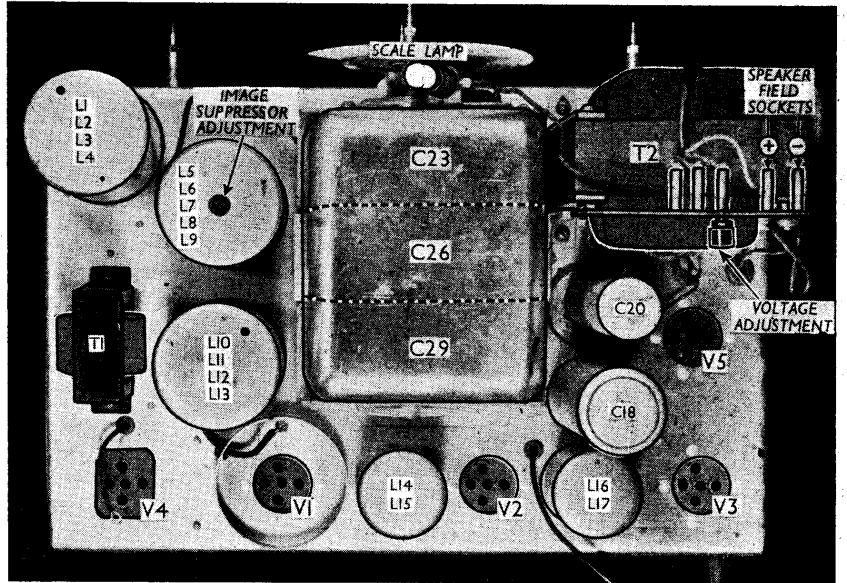

Plan view of the chassis. All the trimmers are indicated in the under-chassis view overleaf. The speaker field leads are plugged into the sockets indicated.

DISMANTLING THE SET

Removing Chassis.—Remove the four control knobs (domed nuts with lock-washers) from the front of the cabinet; withdraw the two speaker plugs from their sockets at the rear of the chassis; withdraw the two speaker field plugs from their sockets on the voltage ad-

justment panel on the mains transformer;

remove the three slotted hexagon head chassis fixing screws (with one large and one small metal washer each).

When replacing, the speaker field lead marked “+” should go in the left-hand field socket, and the negative one in the right.

Removing Speaker.—First remove the chassis as described above, and lay the cabinet face-down on the bench.

Free the field and speech coil leads from the cleats holding them to the speaker mounting batten and the sides of the cabinet;

remove the four round-head screws (with backing plates under the heads, and lock-washers under the nuts) holding the speaker to the wooden batten.

The speaker can now be slid toward the base and removed.

When replacing, the connecting panel should be at the bottom.

VALVE ANALYSIS

Valve voltages and currents given in the table below are those quoted in the makers’ manual. Voltages were measured with a 1,000 ohms-per-volt meter, whose negative lead was connected to chassis, except in the case of **V5**.

When measurements are being made, the gain control should be turned to maximum, and there should be no signal input.

Valve	Anode Voltage (V)	Anode Current (mA)	Screen Voltage (V)	Screen Current (mA)
V1 AC/Pen	100	1.5	40	—
V2 AC/SGVM	200	7.5	80	1.5
V3 AC/HL	140	0.2	—	—
V4 AC/Pen	190	30.0	200	5.0
V5 1807	300†	—	—	—

† Each anode to **T2** HT secondary centre-tap, AC.

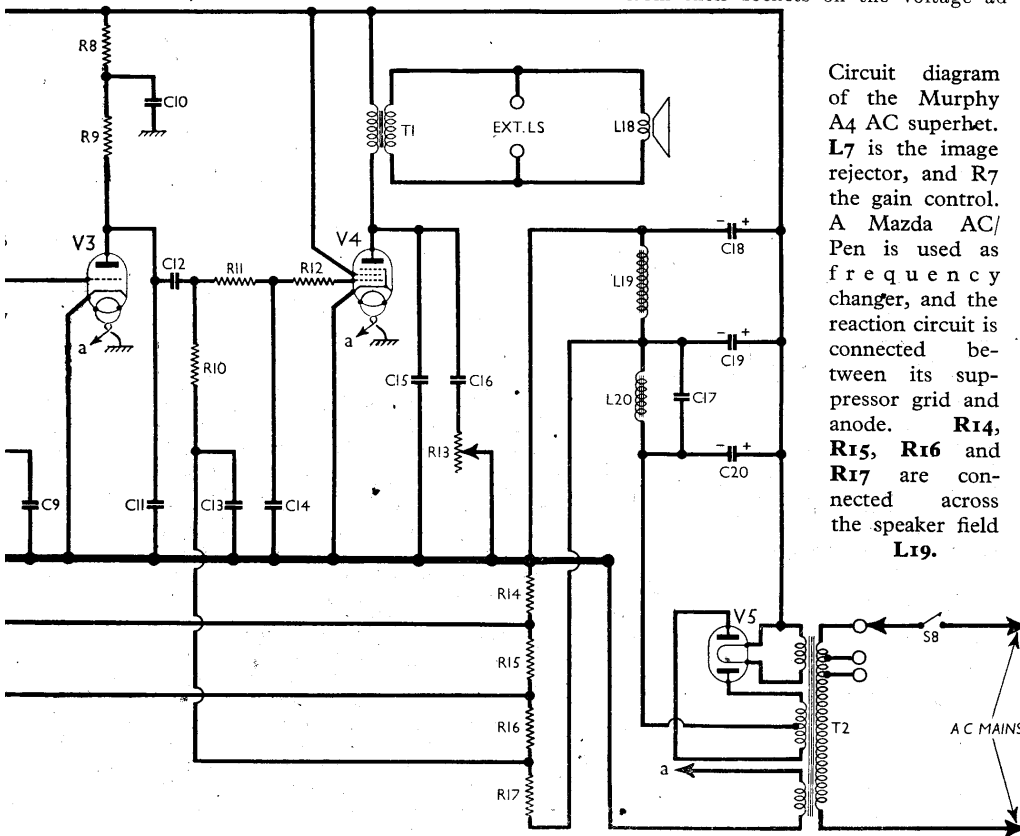

Circuit diagram of the Murphy A4 AC superhet. **L7** is the image rejector, and **R7** the gain control. A Mazda AC/Pen is used as frequency changer, and the reaction circuit is connected between its suppressor grid and anode. **R14**, **R15**, **R16** and **R17** are connected across the speaker field **L19**.

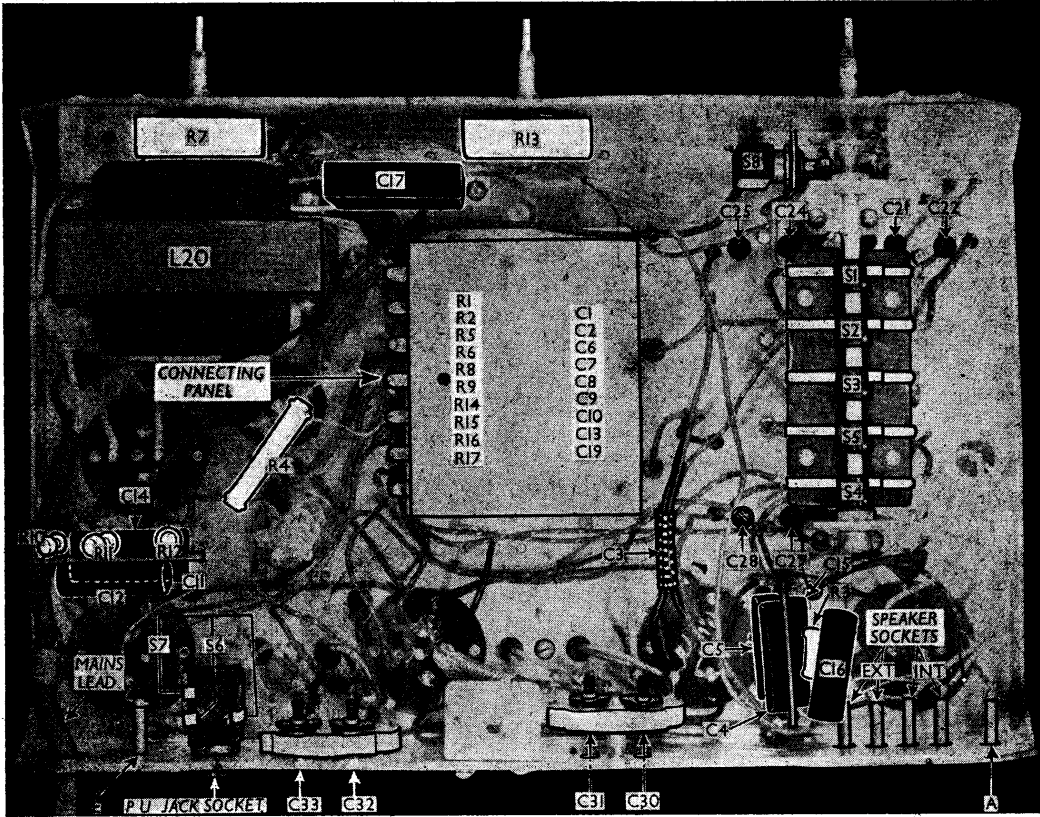

Under - chassis view. All the switches are indicated individually. C3 consists of the capacity between two wires where they are held together by a piece of sleeving. The large component assembly is seen in the centre, and its connecting panel is shown in detail, with the internal connections, in the sketch in cols. 4 and 5. The arrow indicates the direction in which it is viewed in the sketch.

COMPONENTS AND VALUES

RESISTANCES		Values (ohms)
R1	V1 CG decoupling ...	50,000
R2	V1 SG HT feed ...	300,000
R3	V1 anode HT feed ...	50,000
R4	V2 SG and GB potential divider resistances ...	20,000
R5		20,000
R6		200
R7	V2 and aerial gain control ...	8,000
R8	V3 anode decoupling ...	25,000
R9	V3 anode load ...	50,000
R10	V4 CG resistance... ..	150,000
R11		100,000
R12	IF filter resistances ...	100,000
R13	Variable tone control ...	50,000
R14	V1, V3 and V4 GB potential divider resistances ...	15,000
R15		15,000
R16		20,000
R17		400,000

CONDENSERS		Values (μF)
C1	V1 CG decoupling ...	0.1
C2	V1 SG decoupling ...	0.1
C3	Small neutralising coupling ...	Very low
C4	Osc. circuit LW tracker...	0.001373
C5	Osc. circuit MW tracker ...	0.002
C6	V2 SG decoupling ...	0.1
C7	V2 cathode by-pass ...	0.1
C8	V3 CG decoupling condensers ...	0.5
C9		0.1
C10	V3 anode decoupling ...	1.0
C11	IF by-pass ...	0.001
C12	V3 to V4 AF coupling ...	0.025
C13	V4 CG decoupling ...	1.0
C14	IF by-pass condensers ...	0.0002
C15		0.002
C16	Part variable tone control	0.025
C17	L20 shunt... ..	0.1
C18*		8.0
C19*	HT smoothing condensers	1.0
C20*		4.0
C21†	B-P pri. LW trimmer ...	0.00007

* Electrolytic. † Pre-set.

CONDENSERS (Continued)		Values (μF)
C22†	B-P pri. MW trimmer ...	0.00007
C23†	Band-pass pri. tuning ...	0.0005
C24†	B-P sec. LW trimmer ...	0.00007
C25†	B-P sec. MW trimmer ...	0.00007
C26†	Band-pass sec. tuning ...	0.0005
C27†	Osc. circuit LW trimmer ...	0.00007
C28†	Osc. circuit MW trimmer ...	0.00015
C29†	Oscillator circuit tuning ...	0.0005
C30†	1st IF trans. pri. tuning ...	0.00014
C31†	1st IF trans. sec. tuning ...	0.00014
C32†	2nd IF trans. pri. tuning ...	0.00014
C33†	2nd IF trans. sec. tuning ...	0.00014

* Electrolytic. † Variable. ‡ Pre-set.

OTHER COMPONENTS		Approx. Values (ohms)
L1	Aerial coupling coils ...	1.0
L2		8.5
L3	Band-pass primary coils...	6.5
L4		18.5
L5	Band-pass coupling coils...	3.0
L6		0.3
L7	Image suppressor coil ...	Very low
L8	Band-pass secondary coils	6.5
L9		18.5
L10	Osc. MW reaction coil ...	7.0
L11	Osc. LW reaction coil ...	8.5
L12	Osc. circ. MW tuning ...	4.0
L13	Osc. circ. LW tuning ...	15.0
L14		90.0
L15	1st IF trans. { Pri. ...	90.0
L16		Sec. ...
L17	2nd IF trans. { Pri. ...	90.0
L18		Sec. ...
L19	Speaker speech coil ...	2.0
L20	Speaker field coil... ..	2,000.0
T1	HT smoothing choke ...	300.0
	Output { Pri. ...	700.0
	trans. { Sec. ...	0.15
	{ Pri. total ...	42.0
T2	Mains Heater sec. trans. Rect. heat sec. HT sec., total...	0.5 0.72 586.0
S1-S5	Waveband switches	—
S6, S7	Radio/gram change switches	—
S8	Mains switch	—

GENERAL NOTES

Switches.—S1-S5 are the waveband switches, in a cam operated spring-leaf type unit beneath the chassis. The unit is indicated in our under-chassis view, where the individual switches are shown also. All the switches are closed on MW, and open on LW.

S6, S7 are the radio/gram change switches, and form part of the pick-up jack. S6 is closed on radio, and open on gram; S7 is open on radio, and closed on gram. The change-over to gram occurs automatically when the pick-up plug is inserted.

S8 is the QMB mains switch. It is mounted on a bracket, close to the S1-S5 switch spindle, and is operated by the same control.

L20 is the HT smoothing choke, mounted beneath the chassis deck under the mains transformer T2.

Scale Lamp.—This has a tubular bulb and an MES base. A suitable replacement would be a 6.2 V, 0.3 A lamp.

Gramophone Pick-up.—A pick-up jack is provided for this purpose. Switches S6 and S7 are associated with the jack, as described under "Switches." For bias purposes, it is important the pick-up circuit should be continuous, as described in the "Circuit Description." If it is desired to include a condenser, for instance, in the connecting lead, a resistance of about 500,000 Ω to 1,000,000 Ω should be connected across the pick-up connections.

External Speaker.—Four sockets are provided at the rear of the chassis for the connection of a low impedance (2-4 Ω) external speaker and the internal speaker speech coil leads.

MURPHY A90

Output Valve Modification

In some chassis of the Murphy A90 series (Trader Service Sheet No. 513) the original output valve V4 Mazda Pen45 has been replaced by a Mazda Pen45DD, the substitution being made to avoid delay in delivery. The makers suggest that the same modification may be made in the case of the A92, and may also be necessary in the case of other receivers.

For the benefit of those dealers who have access to a Pen45DD, and are unable to obtain the Pen45, the makers' instructions are described below.

Conversion Details

The existing valve holder can be used, but R13 must be removed, and pins 2, 5 and 7 must be connected together. R13 is normally connected between pin 5 of the valve holder and the fourth tag from the left on the connecting strip nearer the underside of the chassis deck, viewing the underside of the chassis when it is in the position shown in our under-chassis view in Service Sheet 513.

It will be necessary to make up a screened lead for the top cap connection, since the Pen45DD has a top cap connector; the length can be gauged roughly on the job. One end of the inner lead should be connected to the tag on connecting strip from which R13 was removed, after passing the end through the nearest available hole in the chassis, or through one drilled specially for it near the valve holder.

The other end of the lead should be terminated in a screened top cap connector, and R13, or a smaller resistance of the same value if the original one is too large for the cap, should be fitted inside the cap and connected in series with the lead. It is important that the valve end of the resistance should be connected by the shortest possible length of wire. Finally, bond the cap screen and lead screen well, and earth the other end of the screen to some convenient point.

Lead Available

The makers are prepared to supply the screened lead already made up and including the resistance and a fixing cleat to hold down the lead beneath the chassis, for those who prefer it.

R13 is the number of the component in question in our Service Sheet; the number of this component in the Murphy manual is R24.

SERVICE SHEET CORRECTION.

In Service Sheet 541, an error unfortunately occurred in "General Notes." In the paragraph commencing "External Speaker" it was stated that a high impedance external speaker could be connected across the primary tags of T1. This should, of course, have been T2: T1 is the intervalve auto-transformer.

Condenser C3.—This is a very small neutralising capacity formed by binding together for a distance of about one to one-and-a-half inches C26 and C29 leads.

Condenser C17.—This is connected in parallel with the HT smoothing choke L20, and tunes it to the mains hum frequency. For this reason, the value of the condenser is 0.1 μ F in the 50 cycle model, and 0.4 μ F in the 25 cycle model.

Condensers C18, C20.—These are two tubular electrolytics mounted on the chassis deck. C18 is an 8 μ F wet electrolytic, rated at 440 V DC working, and 460 V DC peak. Its case is the negative connection. C20 is a 4 μ F dry electrolytic, rated at 500 V peak working, and 550 V surge. Its case is the negative connection, but it is isolated from the chassis by a paxolin washer above the chassis deck. C19 is contained in the enclosed assembly beneath the deck.

Component Assemblies.—Most of the small components are comprised in three assemblies. Two of these consist of a few condensers and resistances mounted on small vertical paxolin panels, beneath the chassis. On one of these are mounted R10, R11, R12, C14 and C11, C12; on the other are R3, C15, C16 and C4, C5.

The third assembly consists of a metal cased unit with a paxolin panel on one side fitted with connecting tags to which junctions between the internal and external components are made. This unit is fitted at about the centre of the underside of the chassis, and contains the following components: resistances R1, R2, R5, R6, R8, R9, R14, R15, R16, R17 and condensers C1, C2, C6, C7, C8, C9, C10, C13, C19. A diagram of the connecting panel, the tags of which are lettered, appears below.

Mains Transformer T2.—The transformer in our chassis was the 200-250 V, 50 cycle type. The DC resistance of the primary winding of 100-110 V, 50 cycle type is 9 ohms; the resistance values of the remaining windings are the same as for the 200-250 V type quoted in our "Other Components" table. The resistance values of the 200-250 V, 25 cycle type are different throughout, and the transformer is larger physically. The winding resistances in this model are as follows: primary, total, 58 ohms; heater secondary, 0.85 ohms; rectifier heater secondary, 1.22 ohms; HT secondary total, 760 ohms.

Valve Noise.—If noise is experienced in the form of frequent small explosive sounds, it is probably due to a noisy frequency changer, and the only cure is to replace V1. Some difficulty has been met

in selecting AC/Pen valves that will operate silently in this position, and if it is possible, a selection should be made from four or five valves. It may, of course, be possible to effect an improvement by transposing V1 and V4, since they are of the same type.

CIRCUIT ALIGNMENT

IF Stages.—Unless a frequency-modulated signal generator and oscilloscope are available, a shunt will be required for the alignment of the IF stages, since their response should have a band-pass characteristic. The shunt may conveniently consist of a 250,000 Ω resistance terminated in spring clips. If a condenser of about 0.1 μ F is connected in series with the resistance, one end of the shunt may be attached to chassis throughout the operation, the other end only being shifted from the high-potential end of one circuit to that of another.

Switch set to LW, turn the gang and gain control to maximum and connect a 0.1 μ F condenser across C29. Connect the signal generator via a 0.1 μ F condenser to V2 control grid, and feed in a 117 KC/S (2,564.2 m) signal. Connect shunt across L16, and adjust C33 for maximum output. Transfer shunt to L17, and adjust C32 for maximum output.

Transfer signal generator lead to V1 control grid (the tag of C25), transfer shunt to L14, and adjust C31. Transfer shunt to L15, and adjust C30 for maximum output. Remove condenser shunting C29, and the damping shunt.

RF and Oscillator Stages.—With the gang at maximum, the 200 m mark on the scale and the mark opposite to it should be vertical. Transfer signal generator leads via a suitable dummy aerial to A and E sockets.

MW.—Switch set to MW, tune to 214 m on scale, feed in a 214 m (1,400 KC/S) signal, and adjust C28, then C22 and C25, for maximum output. Repeat these adjustments until no improvement can be obtained.

LW.—Switch set to LW, tune to 1,000 m on scale, feed in a 1,000 m (300 KC/S) signal, and adjust C27, then C21 and C24, for maximum output. Repeat these adjustments until no improvement can be obtained.

Image Suppressor.—Switch set to MW, feed in a strong 342 m (878 KC/S) signal, tune to 470 m on scale, find the image point by rocking the gang slightly, and adjust the image suppressor adjusting screw in the top of the L5-L9 unit for minimum output.

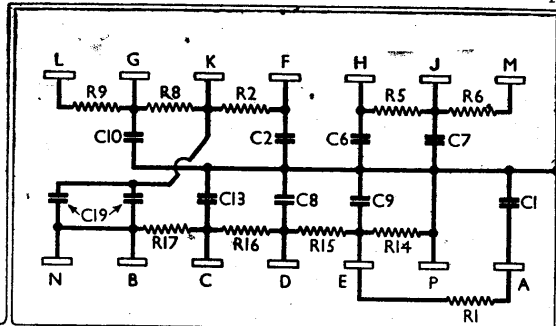

Sketch showing the connecting panel and internal circuit of the large component assembly indicated in the under-chassis view, where an arrow shows the direction in which it is viewed.